



RITE
AID

SITE ADDRESS:

Store #10424

75 South Main Street

Neptune, NJ 07753-5032

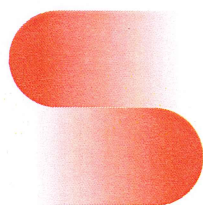

Stratus

stratusunlimited.com

888.503.1569

DUE DILIGENCE

Reviewer:		Zoning:	C-6 Route 33 E Commercial
Master Sign Program (MSP)? Y/N	Yes	Jurisdiction:	Neptune Township
Existing Building SF:		Contact Name:	George Waterman
Existing Freestanding SF:		Address:	25 Neptune Blvd
Proposed Building SF:		City, ST ZIP	Neptune, NJ 07753
Proposed Freestanding SF:		Phone:	732-988-5200 Ext 217
		Email:	gwaterman@naptunetownship.org
WALL SIGNS			
# of Signs Allowed:	This property has a Master Sign Plan. City cannot provide a copy. contact owner for Master Sign Plan	SF based on Lot Frontage, Street Frontage, % Wall Area?	
Max SF:		Max. Height:	
Max. Projection:		Max. Width:	
Can Sign Project above Roof Line?		If Yes, how much?	
Illumination Restrictions?		How is area measured?	
Area transferable to another elevation? (Y/N)		Does elevation require Street Frontage? (Y/N)	
Notes:			
GROUND SIGNS			
Ground Signs Allowed? (Y/N)	No	Pole or Monument?	
Minimum Frontage to Qualify:		# of Signs Allowed:	
Illumination Restrictions?		Max. SF:	
EMCs Allowed? (Y/N)			
EMC Regulations/ Notes:			
DIRECTIONALS			
Directionals Allowed? (Y/N)	No	# of Signs Allowed:	
Permits Required? (Y/N)		Max. SF:	
Directionals count towards allowed SF? (Y/N)		Max. Overall Height:	
Interior Lot Directionals Restricted? (Y/N)		Name/ Logos Allowed? (Y/N)	
Notes:			
PERMIT REQUIREMENTS			
Permits submitted via Mail, Online, or In Person?	All	License Required to submit?	Yes
Permits submitted by Authorized Agent or Contractor?	Either		
Owner, agent or contractor signature required on application?	Both		
Documents and # required for submittal:	2 SET OF PLOT PLAN, INSTALLATION DRAWINGS, BUILDING ELVATIONS, LEGAL DESCRIPTION		
Permit Application Fee:	\$35		
Electrical Permit Fee:	\$35 + fees		
Permit Review Period:	1 - 2 weeks		
Specific Inclusions:	No		
Design Restrictions:	Yes		
Historical Restrictions:	No		
Are Variances Allowed:	No		

StratusTM

stratusunlimited.com

8959 Tyler Boulevard
Mentor, Ohio 44060

888.503.1569

CLIENT:



P.O. NUMBER:

584653

PROJECT NUMBER:

N/A

SITE NUMBER:

10424

PROJECT MANAGER:

REGINA BALTZEGAR

ELECTRONIC FILE NAME:

ACCOUNTS\SR\RITE AID\2020\WJ
10424_Neptune.cdr

ADDRESS:

75 SOUTH MAIN STREET
NEPTUNE, NJ 07753-5032

PAGE NO.

2

Rev #	Rev #	Date/Artist	Description	Rev #	Rev #	Date/Artist	Description
Original	144625	07/29/20 TB					
Rev 1	148035	08/05/20 SC					
Rev 2	148336	8/10/20 SI					
Rev 3	166359	06/03/21 JB					

PRINTS ARE THE EXCLUSIVE PROPERTY OF STRATUS. THIS MATERIAL SHALL NOT BE USED, DUPLICATED, OR OTHERWISE REPRODUCED WITHOUT THE PRIOR WRITTEN CONSENT OF STRATUS.

SITE OVERVIEW



SITE OVERVIEW

E1	Regulatory	1'-0" x 1'-6"
E2	Regulatory	1'-0" x 1'-6"
E3	Regulatory	1'-0" x 1'-6"
E4	Main ID	4'-3" x 12'-6"
E5	Tenant Cabinet	2'-1" x 6'-2"
E6	Regulatory	1'-0" x 1'-6"
E7	Regulatory	1'-0" x 1'-6"
E8	Regulatory	1'-0" x 1'-6"
E9	Regulatory	1'-0" x 1'-6"
E10	Directional	1'-2" x 3'-7"
E11	Hackensack Channel Letters	1'-6" x 17'-8"
E12	Rite Aid Channel Letters	5'-4" x 17'-0"
E13	Pharmacy Flat Panel	1'-0" x 4'-0"
E14	DTP Channel Letters	2'-10" x 14'-8"
E15	Hackensack Channel Letters	1'-6" x 17'-8"
E16	Rite Aid Channel Letters	5'-4" x 17'-0"
E17	Pharmacy Flat Panel	1'-0" x 4'-0"
E18	Enter Channel Letters	1'-4" x 7'-0"
E19	Regulatory	2'-0" x 1'-8"
E20	Exit Channel Letters	1'-4" x 5'-0"

Stratus™

stratusunlimited.com

8999 Tyler Boulevard
Mentor, Ohio 44060
888.503.1569

CLIENT:



ADDRESS:

75 SOUTH MAIN STREET
NEPTUNE, NJ 07753-5032

PAGE NO.

3

P.O. NUMBER:

584653

SITE NUMBER:

10424

ELECTRONIC FILE NAME:
ACCOUNTS/R/RITE AID/2020/WJ/
10424_Neptune.cdr

PROJECT NUMBER:

N/A

PROJECT MANAGER:

REGINA BALTZEGAR

Rev #	Req #	Date/Artist	Description	Rev #	Req #	Date/Artist	Description
Original	144625	07/29/20 TB					
Rev 1	148035	08/05/20 SC					
Rev 2	148336	8/10/20 SI					
Rev 3	166359	06/03/21 JB					

PRINTS ARE THE EXCLUSIVE PROPERTY OF STRATUS. THIS MATERIAL SHALL NOT BE USED, DUPLICATED, OR OTHERWISE REPRODUCED WITHOUT THE PRIOR WRITTEN CONSENT OF STRATUS.

SOUTH ELEVATION

EXISTING

Scale: 1/16" = 1'-0"



Existing signs to be removed; wall to be patched and painted as required

PAINT SCHEDULE 10.9:

- PAINT #1**
 SW 7668 - March Wind
- PAINT #2**
 SW 7017 - Dorian Gray
- PAINT #3**
 SW 7669 - Summit Gray
- PAINT #4**
 Pantone 293 Blue

PROPOSED

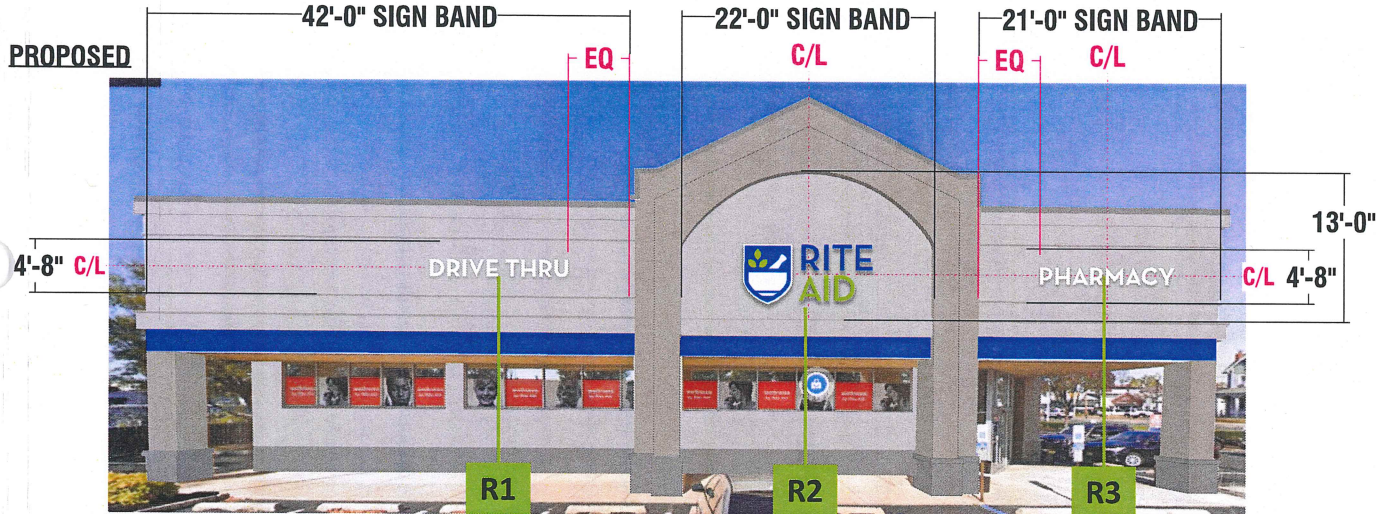

SOUTH ELEVATION

Existing Signage:

Callout	Sign Description	Dimensions	Area (sf)
E11	"Hackensack" CL Set	1'-6" x 17'-8"	26.5 sf
E12	"Rite Aid" CL Set	5'-4" x 17'-0"	90.7 sf
E13	Pharmacy Flat Panel	1'-0" x 4'-0"	4.0 sf
E14	"DTP" CL Set	2'-10" x 14'-8"	41.6 sf
Total Existing Sq. Ft.			162.8

Proposed Signage:

Callout	Sign Description	Dimensions	Area (sf)
R1	RA-DT-3	1'-6" x 11'-11-1/2"	17.9 sf
R2	RA-STKD-2	5'-3-1/4" x 11'-3-1/4"	59.4 sf
R3	RA-PHCY-2	1'-6" x 11'-8-1/4"	17.5 sf
E11	Remove	1'-6" x 17'-8"	
Total Proposed Sq. Ft.			94.8

Total Proposed Sq. Ft. 94.8

Allowable Sq. Ft per elevation: N/A

Stratus™

stratusunlimited.com

8959 Tyler Boulevard
Mentor, Ohio 44060
888.503.1569

CLIENT:



ADDRESS:

75 SOUTH MAIN STREET
NEPTUNE, NJ 07753-5032

PAGE NO.

4

P.O. NUMBER:

584653

SITE NUMBER:

10424

ELECTRONIC FILE NAME:
ACCOUNTS/R/RITE AID/2020/NJ/
10424_Neptune.cdr

PROJECT NUMBER:

N/A

PROJECT MANAGER:

REGINA BALZEGAR

Rev #	Req #	Date/Artist	Description	Rev #	Req #	Date/Artist	Description
Original	144625	07/29/20 TB					
Rev 1	148035	08/05/20 SC	Removed E11 from proposed				
Rev 2	148336	8/10/20 SI					
Rev 3	166359	06/03/21 JB	Updated measurements				

PRINTS ARE THE EXCLUSIVE PROPERTY OF STRATUS. THIS MATERIAL SHALL NOT BE USED, DUPLICATED, OR OTHERWISE REPRODUCED WITHOUT THE PRIOR WRITTEN CONSENT OF STRATUS.

EAST ELEVATION

EXISTING

Scale: 1/16" = 1'-0"



Existing signs to be removed; wall to be patched and painted as required

PAINT SCHEDULE 10.9:

PAINT #1
 SW 7668 - March Wind

PAINT #2
 SW 7017 - Dorian Gray

PAINT #3
 SW 7669 - Summit Gray

PAINT #4
 Pantone 293 Blue

PROPOSED



EAST ELEVATION

Existing Signage:

Req #	Description	Dimensions	Sq. Ft.
E15	"Hackensack" CL Set	1'-6" x 17'-8"	26.5 sf
E16	"Rite Aid" CL Set	5'-4" x 17'-0"	90.7 sf
E17	Pharmacy Flat Panel	1'-0" x 4'-0"	4.0 sf
Total Existing Sq. Ft.			121.2

Proposed Signage:

Req #	Description	Dimensions	Sq. Ft.
R4	RA-STKD-2	5'-3-1/4" x 11'-3-1/4"	59.4 sf
R11	RA-PHCY-2	1'-6" x 11'-8-1/4"	17.5 sf
Total Proposed Sq. Ft.			76.9

Total Proposed Sq. Ft. 76.9

Allowable Sq. Ft per elevation: N/A

Stratus™

stratusunlimited.com

8959 Tyler Boulevard
Mentor, Ohio 44060
888.503.1569

CLIENT:



ADDRESS:

75 SOUTH MAIN STREET
NEPTUNE, NJ 07753-5032

PAGE NO.

5

P.O. NUMBER:

584653

SITE NUMBER:

10424

ELECTRONIC FILE NAME:
ACCOUNT'S/R/RITE AID/2020/NJ
10424_Neptune.cdr

PROJECT NUMBER:

N/A

PROJECT MANAGER:

REGINA BALTZEGAR

Rev #	Req #	Date/Artist	Description	Rev #	Req #	Date/Artist	Description
Original	144625	07/29/20 TB					
Rev 1	148035	08/05/20 SC	Removed E16 from proposed				
Rev 2	148336	8/10/20 SI	Revised to show Pharmacy Sign				
Rev 3	166359	06/03/21 JB	Updated measurements				

PRINTS ARE THE EXCLUSIVE PROPERTY OF STRATUS. THIS MATERIAL SHALL NOT BE USED, DUPLICATED, OR OTHERWISE REPRODUCED WITHOUT THE PRIOR WRITTEN CONSENT OF STRATUS.

R1

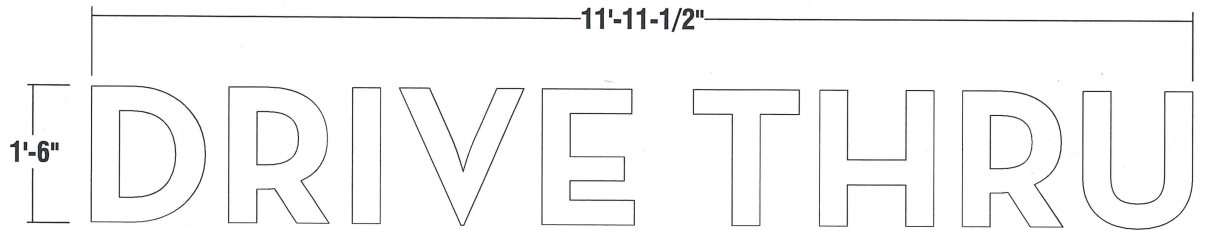

- FACES:** .177 Optix #7328 White acrylic
 - TRIMCAP:** 1" Jewelite trimcap - White
 - RETURNS:** 3" deep .040 alum. painted Semi-gloss White
 - BACK:** 3mm ACM backs - Insides White
 - ILLUM.:** Sloan Prism 5000K White LED modules w/ Remote Power Supplies
-
- INSTALL:** Thru bolted flush to sign band using min 1/4" all thread fasteners into wood blocking - or approved alternate

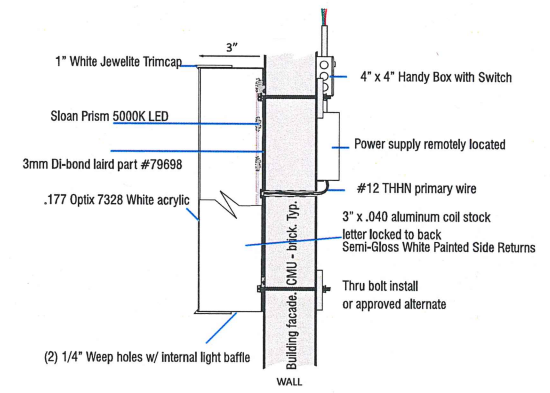

Detail of Channel Letters
N.T.S.

Notes: All penetrations to be sealed with BIOSTOP 500+ Intumescent Firestop Sealant to meet NEC #300.21, ASTM #E814, UL #1479 & UL #2079 standards

stratusunlimited.com
8959 Tyler Boulevard
Mentor, Ohio 44060
888.503.1569

CLIENT:

P.O. NUMBER:
584653

SITE NUMBER:
10424

ELECTRONIC FILE NAME:
ACCOUNTS/R/RITE AID/2020/WA/10424_Neptune.cdr

PROJECT NUMBER:
N/A

PROJECT MANAGER:
REGINA BALTZEGAR

Rev #	Req #	Date/Artist	Description
Original	144625	07/29/20 TB	
Rev 1	148035	08/05/20 SC	
Rev 2	148336	8/10/20 SI	
Rev 3	166359	06/03/21 JB	

ADDRESS:
75 SOUTH MAIN STREET
NEPTUNE, NJ 07753-5032

PAGE NO.:
6

PRINTS ARE THE EXCLUSIVE PROPERTY OF STRATUS. THIS MATERIAL SHALL NOT BE USED, DUPLICATED, OR OTHERWISE REPRODUCED WITHOUT THE PRIOR WRITTEN CONSENT OF STRATUS.

FACE LIT CHANNEL LETTERS

Scale: 3/8" = 1'-0"

RA-STKD-2

Stacked Logo w/ Shield

59.4 Square Feet

R2 R4

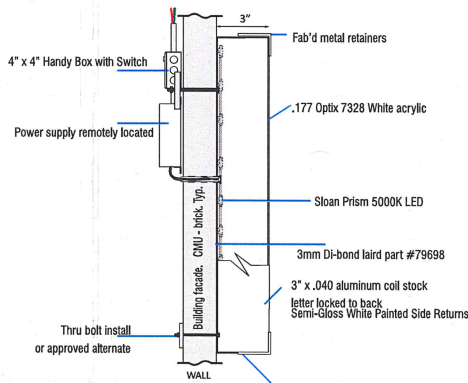

Detail of Shield Logo
N.T.S.

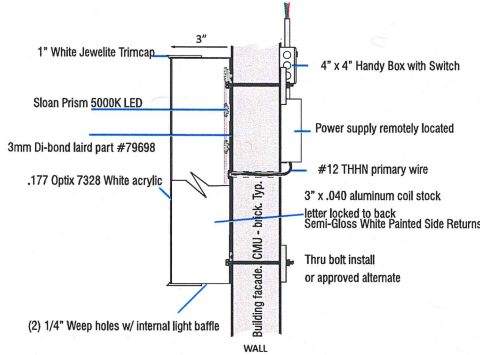

Detail of Channel Letters
N.T.S.

Notes: All penetrations to be sealed with BIOSTOP 500+ Intumescent Firestop Sealant to meet NEC #300.21, ASTM #E814, UL #1479 & UL #2079 standards

NIGHT TIME VIEW



LOGO:
3M 3630-157 Sultan Blue

LOGO:
3M 3630-5317 Green

RITE:
3M 3536-157 Dual Color Sultan Blue

AID:
3M 3635-5317 Dual Color Green

Note: All interior surfaces to be reflective white

SHIELD:

FACE: .177 Optix #7328 semi-gloss white acrylic w/ surface applied Translucent vinyls leaving white illuminated outline

RETAINER: Fabricated 1" metal retainers painted Semi-Gloss White

RETURNS: 3" deep .040 alum. painted Semi-gloss White

BACK: 3mm Dibond back - Laird part #79698

ILLUM.: Sloan Prism 5000K White LED modules w/ Remote Power Supplies

LETTERS:

FACE: .177 Optix #7328 semi-gloss white acrylic w/ surface applied Dual-Color vinyls to illuminate white at night

TRIMCAP: 1" jewelite trimcap - White

RETURNS: 3" deep .040 alum. painted Semi-gloss White

BACK: 3mm Dibond back - Laird part #79698

ILLUM.: Sloan Prism 5000K White LED modules w/ Remote Power Supply

INSTALL: Thru bolted flush to sign band using min 3/8" all thread fasteners into wood blocking - or approved alternate

QUANTITY: (2) TWO SETS REQUIRED FOR SOUTH & EAST ELEVATIONS

1" RETAINER / LARGER INLINE



ORIGINAL LOGO:



StratusTM

stratusunlimited.com

8959 Tyler Boulevard
Mentor, Ohio 44060

888.503.1569



ADDRESS:
75 SOUTH MAIN STREET
NEPTUNE, NJ 07753-5032

PAGE NO.
7

P.O. NUMBER:
584653

SITE NUMBER:
10424

ELECTRONIC FILE NAME:
ACCOUNTS\R\RITE AID\2020\N\A
10424_Neptune.cdr

PROJECT NUMBER:
N/A

PROJECT MANAGER:
REGINA BALZEGAR

Rev #	Req #	Date/Artist	Description	Rev #	Req #	Date/Artist	Description
Original	144625	07/29/20 TB					
Rev 1	148035	08/05/20 SC					
Rev 2	148336	8/10/20 SI					
Rev 3	166359	06/03/21 JB					

PRINTS ARE THE EXCLUSIVE PROPERTY OF STRATUS. THIS MATERIAL SHALL NOT BE USED, DUPLICATED, OR OTHERWISE REPRODUCED WITHOUT THE PRIOR WRITTEN CONSENT OF STRATUS.

FACE LIT CHANNEL LETTERS

RA-PHCY-2

Scale: 3/4" = 1'-0"

17.5 Square Feet

R3 R11



- FACES:** .177 Optix #7328 White acrylic
- TRIMCAP:** 1" Jewelite trimcap - White
- RETURNS:** 3" deep .040 alum. painted Semi-gloss White
- BACK:** 3mm ACM backs - Insides White
- ILLUM.:** Sloan Prism 5000K White LED modules w/ Remote Power Supplies

INSTALL: Thru bolted flush to sign band using min 1/4" all thread fasteners into wood blocking - or approved alternate

QUANTITY: (2) Two sets of channel letters required
 (1) One for South elevation and (1) One for East Elevation

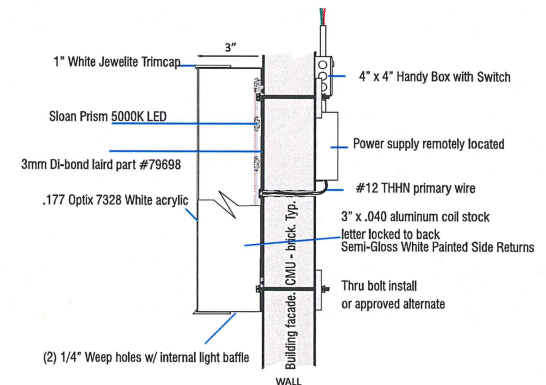

Detail of Channel Letters
 N.T.S.

Notes: All penetrations to be sealed with BIOSTOP 500+ Intumescent Firestop Sealant to meet NEC #300.21, ASTM #E814, UL #1479 & UL #2079 standards

Stratus™

stratusunlimited.com
 8959 Tyler Boulevard
 Mentor, Ohio 44060
 888.503.1569



CLIENT: RITE AID
ADDRESS: 75 SOUTH MAIN STREET
 NEPTUNE, NJ 07753-5032

P.O. NUMBER: 584653
PROJECT NUMBER: N/A
SITE NUMBER: 10424
PROJECT MANAGER: REGINA BALTZEGAR
ELECTRONIC FILE NAME: ACCOUNTS/R/RITE AID/2020/NJ/10424_Neptune.cdr

PAGE NO.
8

Rev #	Req #	Date/Artist	Description	Rev #	Req #	Date/Artist	Description
Original	144625	07/29/20 TB					
Rev 1	148035	08/05/20 SC					
Rev 2	148336	8/10/20 SI	Revised to show 2 Pharmacy Signs				
Rev 3	166359	06/03/21 JB					

PRINTS ARE THE EXCLUSIVE PROPERTY OF STRATUS. THIS MATERIAL SHALL NOT BE USED, DUPLICATED, OR OTHERWISE REPRODUCED WITHOUT THE PRIOR WRITTEN CONSENT OF STRATUS.

DRIVE THRU ELEVATION

EXISTING

Scale: 1/8" = 1'-0"



Existing signs to be removed; wall to be patched and painted as required

PAINT SCHEDULE 10.9 DRIVE THRU:

- PAINT #1**
SW 7668 - March Wind
- PAINT #2**
SW 7017 - Dorian Gray
- PAINT #3**
SW 7669 - Summit Gray
- PAINT #4**
Pantone 293 Blue
- PAINT #5**
White

DRIVE THRU ELEVATION

Existing Signage:

Elevation	Description	Dimensions	Sq. Ft.
E18	"Enter" CL Set	1'-4" x 7'-0"	9.3 sf
E19	Regulatory	2'-0" x 1'-8"	3.3 sf
E20	"Exit" CL Set	1'-4" x 5'-0"	6.7 sf

Total Existing Sq. Ft. 19.3

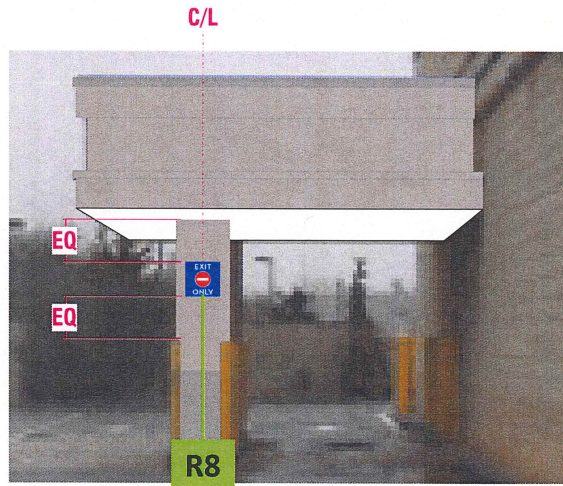
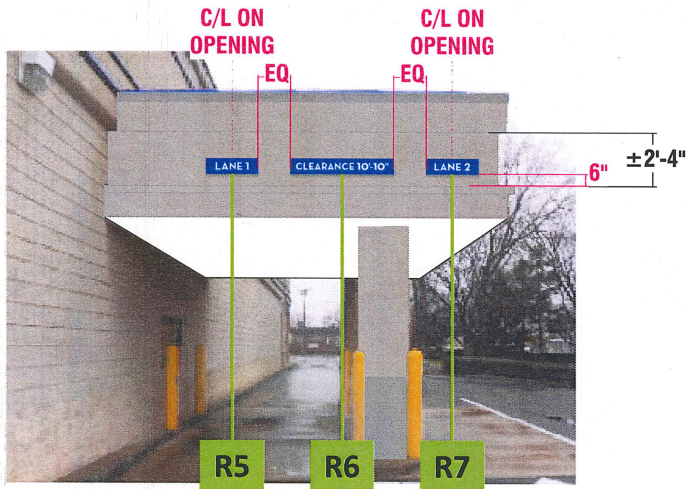

Proposed Signage:

R	Description	Dimensions	Sq. Ft.
R5	RA-DT-LN-1	8" x 2'-3"	1.5 sf
R6	RA-DT-CL	8" x 4'-6"	3 sf
R7	RA-DT-LN-2	8" x 2'-3"	1.5 sf
R8	RA-DT-E0	1'-6" x 1'-6"	2.3 sf
E19	Existing to Remain	2'-0" x 1'-8"	3.3 sf
E20	To Be Removed		

Total Proposed Sq. Ft. 11.6

Allowable Sq. Ft per elevation: N/A

Stratus™

stratusunlimited.com
8959 Tyler Boulevard
Mentor, Ohio 44060
888.503.1569



CLIENT: RITE AID
ADDRESS: 75 SOUTH MAIN STREET
NEPTUNE, NJ 07753-5032

P.O. NUMBER: 584653
PROJECT NUMBER: N/A
SITE NUMBER: 10424
PROJECT MANAGER: REGINA BALZEGAR
ELECTRONIC FILE NAME: ACCOUNTS\RV\RITE AID\2020\W\A\10424_Neptune.cdr

PAGE NO. 9

Rev #	Req #	Date/Init	Description	Rev #	Req #	Date/Init	Description
Original	144625	07/29/20 TB					
Rev 1	148035	08/05/20 SC	RA-DTD-E0 added				
Rev 2	148336	8/10/20 SI					
Rev 3	166359	06/03/21 JB	Updated measurements				

POINTS ARE THE EXCLUSIVE PROPERTY OF STRATUS. THIS MATERIAL SHALL NOT BE USED, DUPLICATED, OR OTHERWISE REPRODUCED WITHOUT THE PRIOR WRITTEN CONSENT OF STRATUS.

RA-DT-LN-1
1.5 Square Feet

R5



RA-DT-CL
3 Square Feet

R6



RA-DT-LN-2
1.5 Square Feet

R7



FACES: .125 aluminum faces painted PMS 293 Blue
GRAPHICS: Surface applied vinyl graphics
INSTALL: Flush mounted to wall using mechanical fasteners painted to match bkgd
QUANTITY: (1) ONE OF EACH LAYOUT

 **CABINET/ POLES:**
Pantone 293 Blue

 **COPY:**
3M 680-10 Reflective White

StratusTM

stratusunlimited.com

8959 Tyler Boulevard
Mentor, Ohio 44060
888.503.1569

CLIENT:



P.O. NUMBER:

584653

PROJECT NUMBER:

N/A

SITE NUMBER:

10424

PROJECT MANAGER:

REGINA BALZEGAR

ADDRESS:

75 SOUTH MAIN STREET
NEPTUNE, NJ 07753-5032

PAGE NO.

10

ELECTRONIC FILE NAME:
ACCOUNTS\WRITE AID\2020\N\10424_Neptune.cdr

Rev #	Rev #	Date/Artist	Description	Rev #	Rev #	Date/Artist	Description
Original	144625	07/29/20 TB					
Rev 1	148035	08/05/20 SC	RA-DTD-EO added				
Rev 2	148336	8/10/20 SI					
Rev 3	166359	06/03/21 JB					

PRINTS ARE THE EXCLUSIVE PROPERTY OF STRATUS. THIS MATERIAL SHALL NOT BE USED, DUPLICATED, OR OTHERWISE REPRODUCED WITHOUT THE PRIOR WRITTEN CONSENT OF STRATUS.

RA-DT-E0

2.3 square feet

Scale: 1-1/2" = 1'-0"

R8

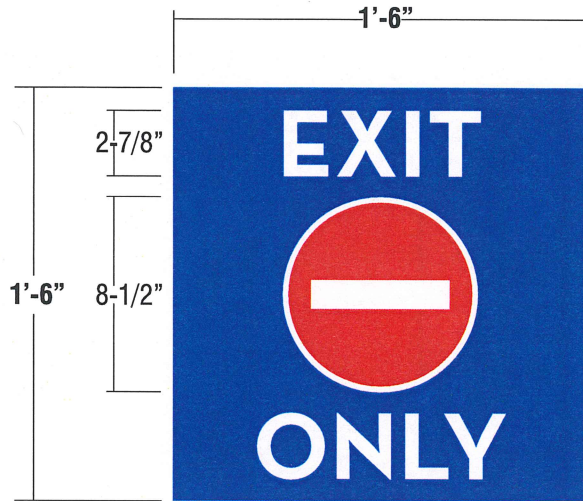

FACE: .125 aluminum faces painted PMS 293 Blue

GRAPHICS: Surface applied vinyl graphics

INSTALL: Flush mounted to wall using mechanical fasteners painted to match bkgd

 **CABINET/ POLES:**
Pantone 293 Blue

 **DO NOT ENTER:**
vinyl to match Pantone 485 Red

 **COPY:**
3M 680-10 Reflective White

StratusTM

stratusunlimited.com

8959 Tyler Boulevard
Mentor, Ohio 44060
888.503.1569

CLIENT: 

ADDRESS: 75 SOUTH MAIN STREET
NEPTUNE, NJ 07753-5032

P.O. NUMBER: 584653

SITE NUMBER: 10424

ELECTRONIC FILE NAME: ACCOUNTS\WRITE AID\2020\NJ\10424_Neptune.cdr

PROJECT NUMBER: N/A

PROJECT MANAGER: REGINA BALTZEGAR

PAGE NO. 11

Rev #	Req #	Date/Artist	Description	Rev #	Req #	Date/Artist	Description
Original	144625	07/29/20 TB					
Rev 1	148035	08/05/20 SC					
Rev 2	148336	8/10/20 SI					
Rev 3	166359	06/03/21 JB					

POINTS ARE THE EXCLUSIVE PROPERTY OF STRATUS. THIS MATERIAL SHALL NOT BE USED, DUPLICATED, OR OTHERWISE REPRODUCED WITHOUT THE PRIOR WRITTEN CONSENT OF STRATUS.

FACE REPLACEMENTS

Scale: 1/2" = 1'-0"

RA-FA-FX

49.2 Square Feet

R9

PANAFLEX SIGN FACE
Material to be overlaid minimum 1" all sides to allow for mounting & securing to sign face



- CABINET:** Existing cabinet with bleed retainers to remain
- FACES:** 3M Panagraphics III White Flexible Substrate
- GRAPHICS:** Vinyl graphics to match colors shown
- ATTACH:** Use existing attachment
- QUANTITY:** (2) TWO FACES REQUIRED FOR EXISTING D/F ILLUMINATED PYLON

-  **LOGO/COPY:**
3M 3630-157 Sultan Blue
-  **LOGO/COPY:**
3M 3630-5317 Green
-  **CABINET/POLE/RETAINERS:**
SW 7668 - March Wind

Stratus™

stratusunlimited.com

8959 Tyler Boulevard
Mentor, Ohio 44060
888.503.1569



CLIENT:
75 SOUTH MAIN STREET
NEPTUNE, NJ 07753-5032

PAGE NO.:
13

P.O. NUMBER:
584653

SITE NUMBER:
10424

ELECTRONIC FILE NAME:
ACCOUNTS/R/RITE AID/2020/NJ/
10424_Neptune.cdr

PROJECT NUMBER:
N/A

PROJECT MANAGER:
REGINA BALTZEGAR

Rev #	Req #	Date/Artist	Description	Rev #	Req #	Date/Artist	Description
Original	144625	07/29/20 TB					
Rev 1	148035	08/05/20 SC	Removed red note				
Rev 2	148336	8/10/20 SI					
Rev 3	166359	06/03/21 JB					

PRINTS ARE THE EXCLUSIVE PROPERTY OF STRATUS. THIS MATERIAL SHALL NOT BE USED, DUPLICATED, OR OTHERWISE REPRODUCED WITHOUT THE PRIOR WRITTEN CONSENT OF STRATUS.

DIRECTIONAL

EXISTING

Scaled Proportionally



EXISTING SIGNAGE TO BE REMOVED & REPLACED

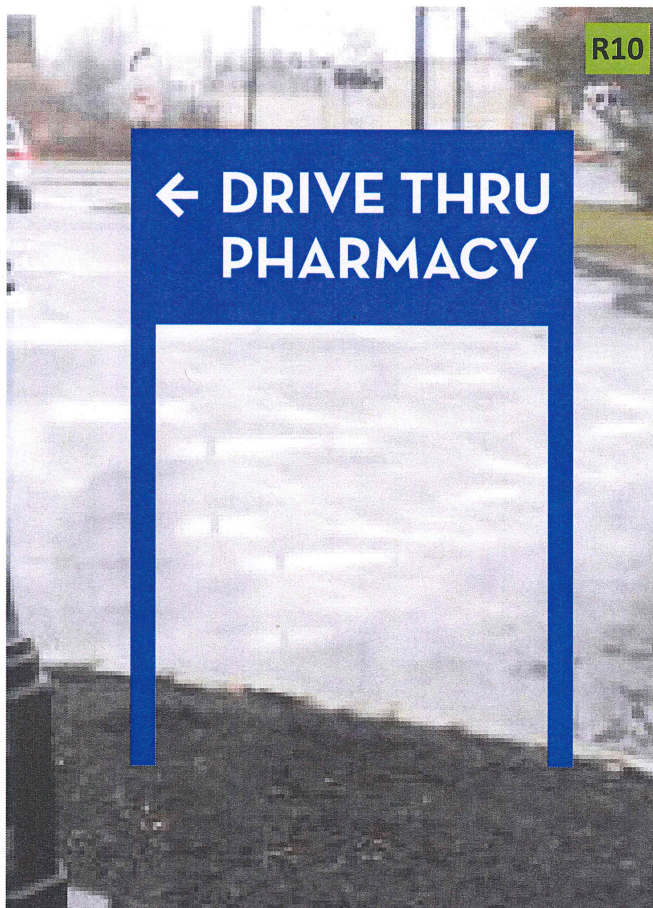

DIRECTIONAL

Existing Signage:

Item #	Directional	Size	Sq. Ft.
E10	Directional	1'-2" x 3'-7"	4.2 sf

Total Existing Sq. Ft. 4.2

Proposed Signage:

Item #	Directional	Size	Sq. Ft.
R10	RA-DRCT	1'-4" x 3'-0" (4'-4" OAH)	4 sf

Total Proposed Sq. Ft. 4

Stratus™
 stratusunlimited.com
 8999 Tyler Boulevard
 Mentor, Ohio 44060
 888.503.1569

CLIENT: RITE AID
ADDRESS: 75 SOUTH MAIN STREET
 NEPTUNE, NJ 07753-5032

P.O. NUMBER: 584653
SITE NUMBER: 10424
ELECTRONIC FILE NAME: ACCOUNTS\R\RITE AID\2020\NJ\10424_Neptune.cdr

PROJECT NUMBER: N/A
PROJECT MANAGER: REGINA BALZEGAR

Rev #	Req #	Date/Artist	Description
Original	144625	07/29/20 TB	
Rev 1	148035	08/05/20 SC	
Rev 2	148336	8/10/20 SI	
Rev 3	166359	06/03/21 JB	

Rev #	Req #	Date/Artist	Description

PRINTS ARE THE EXCLUSIVE PROPERTY OF STRATUS. THIS MATERIAL SHALL NOT BE USED, DUPLICATED, OR OTHERWISE REPRODUCED WITHOUT THE PRIOR WRITTEN CONSENT OF STRATUS.

D/F DIRECTIONAL SIGNAGE

Scale: 3/4" = 1'-0"

RA-DRCT

4 Square Feet

R10

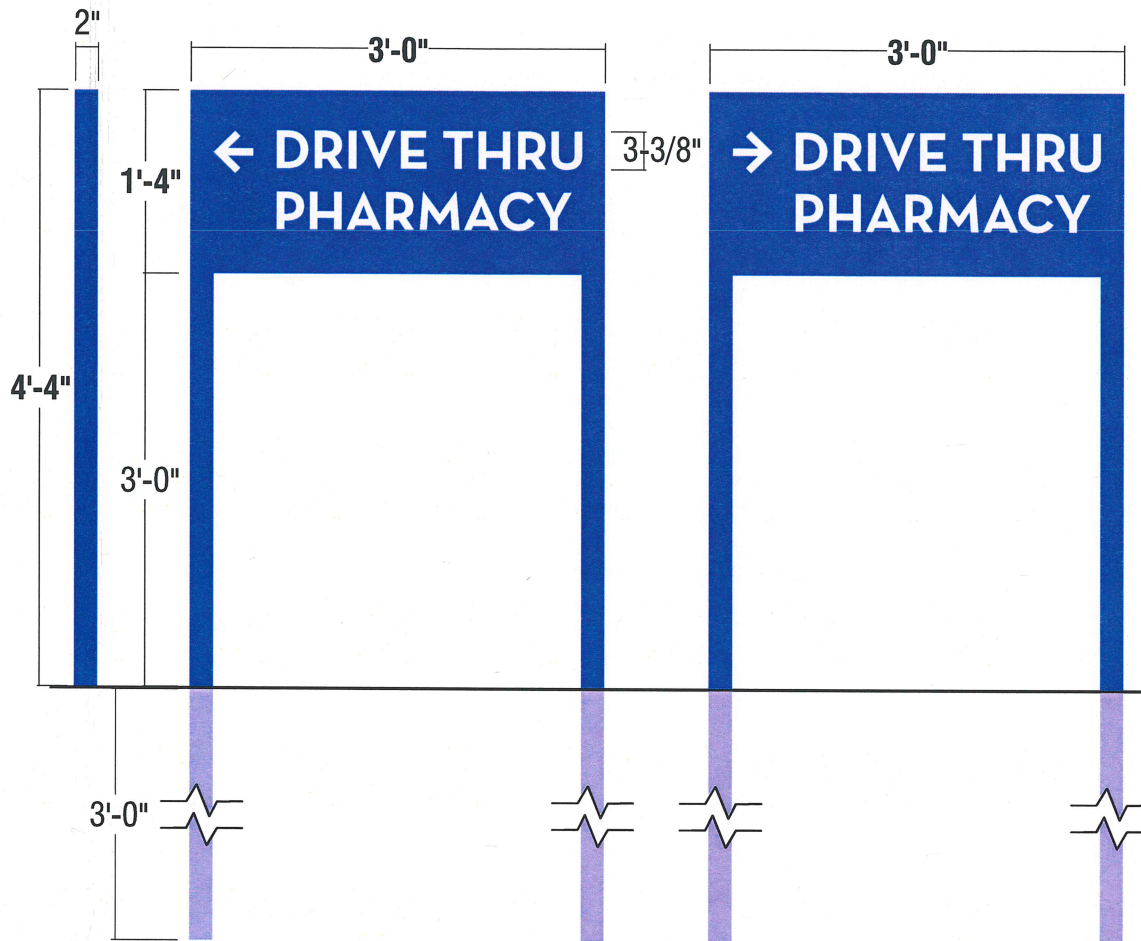

- FACES:** .090 aluminum faces - Painted Pantone 293 Blue
- GRAPHICS:** Surface applied vinyl graphics
- POLES:** 2" square aluminum tubes - Painted Pantone 293 Blue
- INSTALL:** Direct burial installation as required by city code & engineering recommendations
- QUANTITY:** (1) ONE D/F DIRECTIONAL REQUIRED

-  **CABINET/ POLES:**
Pantone 293 Blue
-  **COPY:**
3M 680-10 Reflective White

Stratus™

stratusunlimited.com
8959 Tyler Boulevard
Mentor, Ohio 44060
888.503.1569



CLIENT: **RITE AID**
ADDRESS: 75 SOUTH MAIN STREET
NEPTUNE, NJ 07753-5032

PAGE NO. 15

P.O. NUMBER: 584653
PROJECT NUMBER: N/A
SITE NUMBER: 10424
PROJECT MANAGER: REGINA BALTZEGAR
ELECTRONIC FILE NAME: ACCOUNTS\R\RITE AID\2020\NJ\10424_Neptune.cdr

Rev #	Req #	Date/Artist	Description	Rev #	Req #	Date/Artist	Description
Original	144625	07/29/20 TB					
Rev 1	148035	08/05/20 SC					
Rev 2	148336	8/10/20 SI					
Rev 3	166359	06/03/21 JB					

PRINTS ARE THE EXCLUSIVE PROPERTY OF STRATUS. THIS MATERIAL SHALL NOT BE USED, DUPLICATED, OR OTHERWISE REPRODUCED WITHOUT THE PRIOR WRITTEN CONSENT OF STRATUS.

REGULATORY SIGNAGE

NTS - Not To Scale

EXISTING



E1 E2 E3 E6 E7 E8 E9

EXISTING SIGNAGE TO REMAIN AS-IS

DIRECTIONAL

Existing Signage:

E1	Regulatory	1'-0" x 1'-6"	1.5 sf
E2	Regulatory	1'-0" x 1'-6"	1.5 sf
E3	Regulatory	1'-0" x 1'-6"	1.5 sf
E6	Regulatory	1'-0" x 1'-6"	1.5 sf
E7	Regulatory	1'-0" x 1'-6"	1.5 sf
E8	Regulatory	1'-0" x 1'-6"	1.5 sf
E9	Regulatory	1'-0" x 1'-6"	1.5 sf

Total Existing Sq. Ft. 10.5 (1.5 each)

Proposed Signage:

E1	Regulatory	1'-0" x 1'-6"	1.5 sf
E2	Regulatory	1'-0" x 1'-6"	1.5 sf
E3	Regulatory	1'-0" x 1'-6"	1.5 sf
E6	Regulatory	1'-0" x 1'-6"	1.5 sf
E7	Regulatory	1'-0" x 1'-6"	1.5 sf
E8	Regulatory	1'-0" x 1'-6"	1.5 sf
E9	Regulatory	1'-0" x 1'-6"	1.5 sf

Total Proposed Sq. Ft. 10.5 (1.5 each)

Stratus™

stratusunlimited.com
8959 Tyler Boulevard
Mentor, Ohio 44060
888.503.1569



CLIENT: RITE AID
ADDRESS: 75 SOUTH MAIN STREET
NEPTUNE, NJ 07753-5032

PAGE NO. 16

P.O. NUMBER: 584653
PROJECT NUMBER: N/A
SITE NUMBER: 10424
PROJECT MANAGER: REGINA BALZEGAR
ELECTRONIC FILE NAME: ACCOUNTS\R\RITE AID\2020\NJ\10424_Neptune.cdr

Rev #	Req #	Date/Artist	Description	Rev #	Req #	Date/Artist	Description
Original	144625	07/29/20 TB					
Rev 1	148035	08/05/20 SC					
Rev 2	148336	8/10/20 SI					
Rev 3	166359	06/03/21 JB					

PRINTS ARE THE EXCLUSIVE PROPERTY OF STRATUS. THIS MATERIAL SHALL NOT BE USED, DUPLICATED, OR OTHERWISE REPRODUCED WITHOUT THE PRIOR WRITTEN CONSENT OF STRATUS.